



MARCH 1999

RPO No: 8148 →

REF.

1

No XM - 6



XUD11 ENGINE

(2.1 Turbo D)

- EVOLUTION:
EXHAUST LINE

"The technical information contained in this document is intended for the exclusive use of the trained personnel of the motor vehicle repair trade. In some instances, the information could concern the security and safety of the vehicle. The information is to be used by the professional vehicle repairers for whom it is intended and they alone would assume full responsibility to the exclusion of that of the manufacturer".

"The technical information appearing in this brochure is subject to updating as the characteristics of each model in the range evolve. Motor vehicle repairers are invited to contact the CITROËN network periodically for further information and to obtain any possible updates".

MAN 108931



GB



AUTOMOBILES CITROËN
DIRECTION EXPORT EUROPE
DOCUMENTATION APRÈS VENTE

EVOLUTION : EXHAUST LINE

Vehicle concerned : XM 2.1 Turbo D12 (L3 emission standard).

Applicable from RPO number : 8148.

1 - PRESENTATION

The intermediate pipe of the exhaust pipe is replaced by a pipe without an expansion box.

NOTE : This development does not affect performance (noise, power).

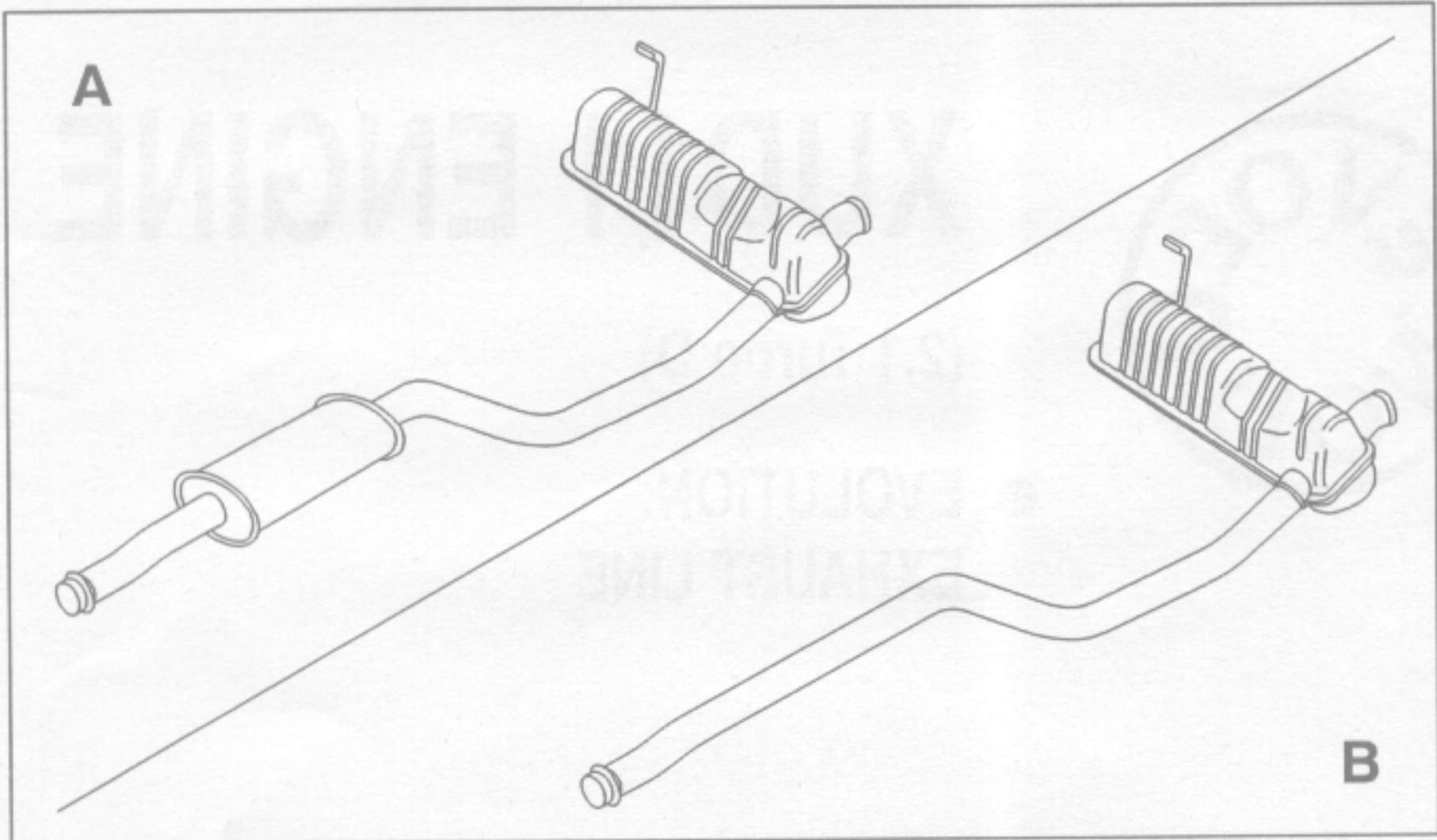

Fig : B1JP027D

A : old part (item "PSA 3340").

B : new part (without make).

The way in which the new part is mounted has not changed.

The other components of the exhaust system have not changed.

2 - REPLACEMENT PARTS

Parts supplied by the Replacement Parts Division : old parts (only).